

FEATURES & APPLICATIONS

- ❖ In-line PV charge controller, eliminates the need for blocking diodes
- ❖ Micro-controller for digital accuracy and reliability
- ❖ Fully automatic operation on 12V or 24V DC systems
- ❖ Built-in Temperature compensation
- ❖ LED indication of Solar charge
- ❖ Will handle up to 10 Amps @ 28V DC from PV panels
- ❖ Sealed / Flooded batteries selectable
- ❖ Pulse action reduces battery sulfation

DESCRIPTION & OPERATION

The PVCM10 photo-voltaic (PV) charge controller is used to connect PV panels to 12V or 24V DC storage batteries. The PVCM determines which mode to operate in, 12V or 24V, by measuring the battery voltage that powers it.

The PVCM10 performs four basic battery charging functions:

- * It senses when the battery is fully charged and disconnects the PV charge current to avoid over-charging the battery.
- * It resumes charging the battery when the battery voltage has dropped sufficiently to accept additional charge current.
- * It checks the availability of PV charge current, by cycling the relay every 4 minutes. If there is insufficient charge current available, it's internal relay will disconnect the battery to prevent discharge through the PV panels at night.
- * It also compensates for battery temperature and adjusts the charge threshold voltages when mounted in battery case.

The Temperature Compensation work as follows: (lead acid)

below 0°C	On @ 13.3VDC	Off @ 15.0VDC
between 0-5°C	On @ 13.3VDC	Off @ 14.8VDC
between 5-10°C	On @ 13.1VDC	Off @ 14.6VDC
between 10-15°C	On @ 12.9VDC	Off @ 14.4VDC
between 15-30°C	On @ 12.7VDC	Off @ 14.2VDC
between 30-35°C	On @ 12.7VDC	Off @ 14.0VDC
between 35-40°C	On @ 12.6VDC	Off @ 13.8VDC
between 40-45°C	On @ 12.6VDC	Off @ 13.6VDC

Temperatures > 45°C (the PVCM10 is mounted in the back of a solar panel) On @ 12.7VDC, Off @ 14.2VDC.

WIRING CONFIGURATION

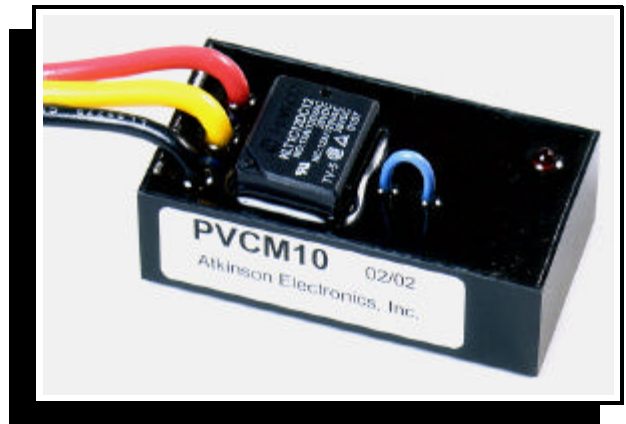
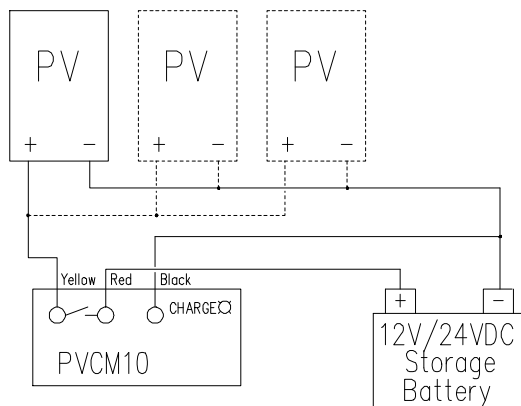

SPECIFICATIONS

SIZE:	0.875 x 3.2 x 1.2 inches
WEIGHT:	3 ounces
ENCLOSURE:	Epoxy potted in PVC plastic
MOUNTING:	Double stick tape
POWER:	6 to 30 V DC from storage battery
LOAD CAPACITY:	12 Amps @ 14V DC 10 Amps @ 28V DC (minimum is a 5 watt panel)
VENTED BATTERY THRESHOLDS:	@ Room Temperature 15-30°C On @ 12.7VDC, Off @ 14.2VDC On @ 25.4VDC, Off @ 28.4VDC Accuracy ± 0.1V DC
SEALED BATTERY THRESHOLDS:	*Blue Jumper clipped* @ Room Temperature 15-30°C On @ 12.4VDC, Off @ 13.9VDC On @ 24.8VDC, Off @ 27.8VDC Accuracy ± 0.1V DC
CURRENT DRAW:	Continuous - ≤ 6mA During charge - ≤ 35mA
LED INDICATION:	Charging Mode - RED
VOLTAGE DROP:	0.05V DC @ 10 Amps
MINIMUMS:	Charge current - 80mA Open PV Voltage - 16V or 32V DC
TEMPERATURE:	-30 to 75°C
RELAY LIFE:	100 million mechanical operations

INSTALLATION TIPS

1. Exposed connections should be waterproofed. Grease or silicon will adequately protect connections such as splices. Clip blue jumper wire for sealed batteries.
2. When wiring the PV panel into the battery system, adequate wire size must be used. 12 AWG or larger wire is recommend. If smaller wire is used, the battery may not achieve full charge.
3. Check the battery fluid level occasionally (at least every 90 days) and add water as necessary.
4. Install the PVCM10 in the Battery enclosure for the temperature compensation to work properly.

TROUBLESHOOTING TIPS

- | | |
|----------|--|
| Problem | - Module doesn't click on and there is sunlight on the PV panels. |
| Solution | - Verify that the battery voltage is less than 12.75V (or 25.5V on a 24VDC system) and that the open PV voltage is greater than 16V (or 32V). If both conditions are met, then wait for 4 minute delay period. |
| Problem | - Module clicks every several minutes. |
| Solution | - This is the normal operating sequence. |
| Problem | - Module charges for a few seconds then shuts off for 4 minutes. |
| Solution | - The Batteries are fully charged and the charge current was at maximum output. It may also mean that the Batteries have a poor connection or a bad cell with high internal resistance. |
| Problem | - Module switches on for 1 or 2 minutes and then is off for a much longer period of time. |
| Solution | - This is also normal if the battery is at or nearly fully charged and the PV charge current is at or near maximum. |
| Problem | - The battery load has been left on and the storage battery has discharged below 6 V DC. The PV system is not charging when the load is turned off. |
| Solution | - The PVCM10 needs at least 6 V DC from the battery to operate properly. Place panel in direct sunlight and jumper the red and yellow wires for a few minutes, thus bypassing the charge controller allowing the battery voltage to rise to at least 7 V DC. Disconnecting the jumper will allow the PVCM10 to charge the battery up to normal levels. |

MOUNTING AT PHOTO-VOLTAIC PANEL

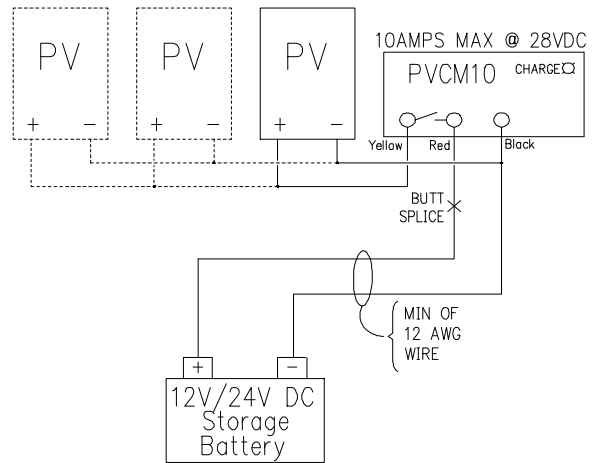

Before mounting the PVCM10 regulator inside the PV panel junction box, clean the surface to which the PVCM10 will be attached. Allow the surface to dry. Remove the backing from the double stick tape and press firmly into box cover.

Note: The temperature compensation function reverts to On @ 12.7VDC Off @ 14.2VDC for temps above 45°C.

MOUNTING AT BATTERY LOCATION

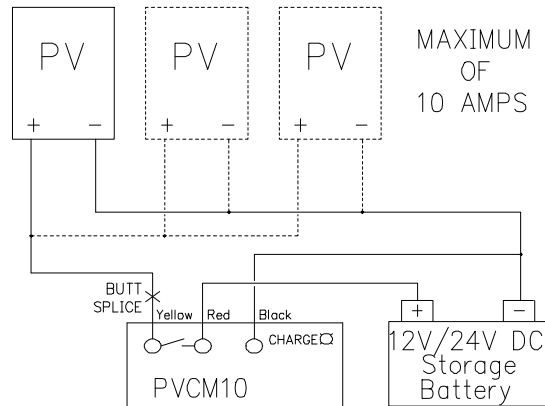

Connect the PVCM10 regulator wires to battery terminals and attach regulator to battery cables with a tie-wrap.

ORDERING INFORMATION

- PVCM10** - Photo-Voltaic charge controller module
 Rated for 10 Amps @ 28VDC,
 12 Amps @ 14VDC.